

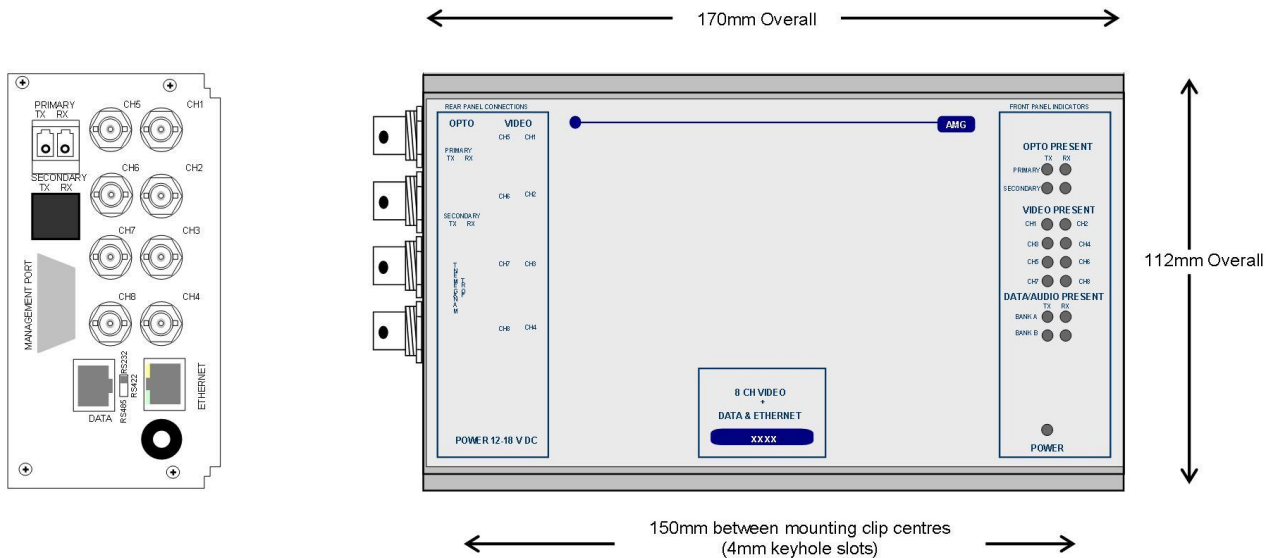

# AMG3684BxE-DR-SF Instruction Manual

## 8 Channel Video Receive Unit with 2 Bi-directional Data and Audio Channels plus Ethernet for a Dual Redundant multimode fibre ring.



The **AMG3684BxE-DR-SF** is a standalone eight channel video receive unit designed to receive up to 8 video signals from a single fibre multimode optical fibre ring with Dual Redundant operation. It also provides 2 bi-directional data/audio channels via a low speed data interface plus full duplex 100BaseT Ethernet connectivity around the ring.

The **AMG3684BxE-DR-SF** is designed to be powered using an **AMG2003** standalone power supply.

The **AMG3684BxE-DR-SF** is designed to operate with up to eight **AMG3613BxE-DR-SF** single channel video insert units. Each receiver will 'drop off' up to eight video channels which are being transmitted around the fibre ring. The **AMG3684BxE-DR-SF** may also be used with other combinations of single, dual or four channel video and data insert units.

# Contents

<b>Introduction</b>	<b>3</b>
Unit Functional Schematic.....	3
Video Input Channel Configuration .....	3
Dual Redundant Operation.....	3
<b>Optical Connections</b>	<b>4</b>
<b>Connections</b>	<b>5</b>
Video Output Connections.....	5
Optical Connections .....	5
Power Connection .....	5
Data and Audio Channel Connections .....	5
Ethernet Connection .....	6
<b>Front Panel Indicators</b>	<b>7</b>
Power LED.....	7
Video Output LED's .....	7
Fibre Optic LED's .....	7
Low Speed Data LEDs .....	7
<b>Ethernet Operation</b>	<b>9</b>
<b>Data and Audio Channel Configuration</b>	<b>10</b>
Data and Audio Channel Configuration.....	10
Data Interface Connections Channel A .....	10
Data Channel A Configuration.....	10
Data / Audio Channel B Configuration .....	11
Data Interface Daughter Board Options .....	11
Audio / Data Interface Connections RJ45 - Channel B .....	11
<b>Physical Information</b>	<b>12</b>
Dimensions .....	12
Mounting Details.....	12
Removal / replacement from / to the Case.....	12
<b>Safety</b>	<b>12</b>
<b>Maintenance and Repair</b>	<b>12</b>

## Introduction

### Unit Functional Schematic

The **AMG3684BxE-DR-SF** drops off up to 8 video and 2 data and audio signals transmitted from the **AMG3613BxE-DR-SF**.

It also transmits up to 2 data and audio channels to the **AMG3613BxE-DR-SF**.

Ethernet connectivity is also provided between the two units.

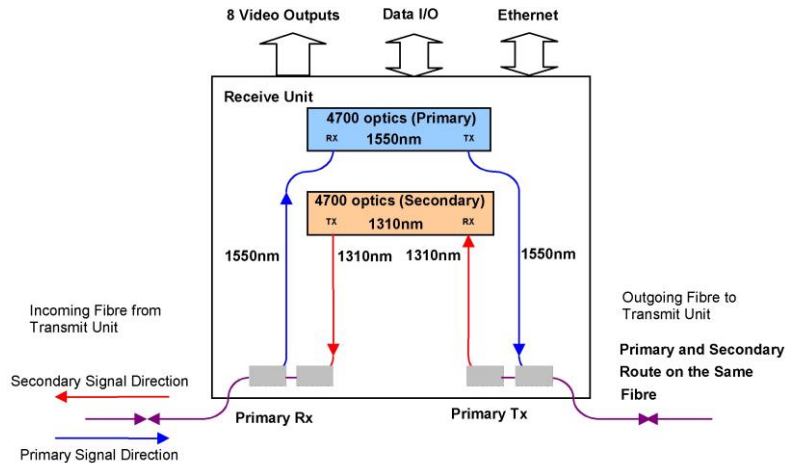

As each unit regenerates the optical signal, the optical dynamic range between each optically connected node is 17dB.

### Video Input Channel Configuration

At the **AMG3613BxE-DR-SF** or rackmount **AMG3613BxE-DR-SF** insert unit, video signals present at the BNC inputs can be inserted on one to eight video channels transmitted on the optical fibre. The first video channel number of each insert unit is set by the rotary switch on the front panel of the unit.

It is normal to set each insert unit to a different channel number. If the same number is used twice, an insert unit connected 'down stream' on the primary optical route will 'over-write' any coincident video channels coming from the previous insert unit and those video signals will be lost.

The switch channel numbers 1 to 8, correspond to video channels 1-8. Unused switch channel numbers 0 & 9 duplicate video channel selections 1 & 8 respectively. i.e. setting switch to position 0 or 1 selects video channel 1 and setting switch to position 8 or 9 selects channel 8.

### Dual Redundant Operation

In normal operation where optical connection to both the previous unit and subsequent insert units is OK, video and data signals are transmitted on the primary output and data is received from the primary input. The secondary optical input is independent and is regenerated on the secondary output.

If the primary input signal is not present, a unit will shut down the secondary output to inform the previous unit that the signal route is not OK. The previous unit will then send out the video and data signals on its secondary output in the opposite direction. This signal will be repeated around the ring to get back to this unit on the secondary route. As the primary input is not present on this unit, the data signal will now be taken from the secondary optical input thus maintaining integrity of the data transmission.

If the secondary input signal is not present, an insert unit will assume that the route to the next unit is not OK and send out the video and data signal on the secondary optical output. This video and data will be transmitted to the next unit around the ring in the opposite direction on the secondary route.

## Optical Connections

The **AMG3684BxE-DR-SF** or rackmount **AMG3684BxE-DR-SF** is designed to be connected in a ring or point to point system. In a ring system, single, dual and four channel insert units respectively can be combined to make up an 8 channel video transmission system as illustrated below.

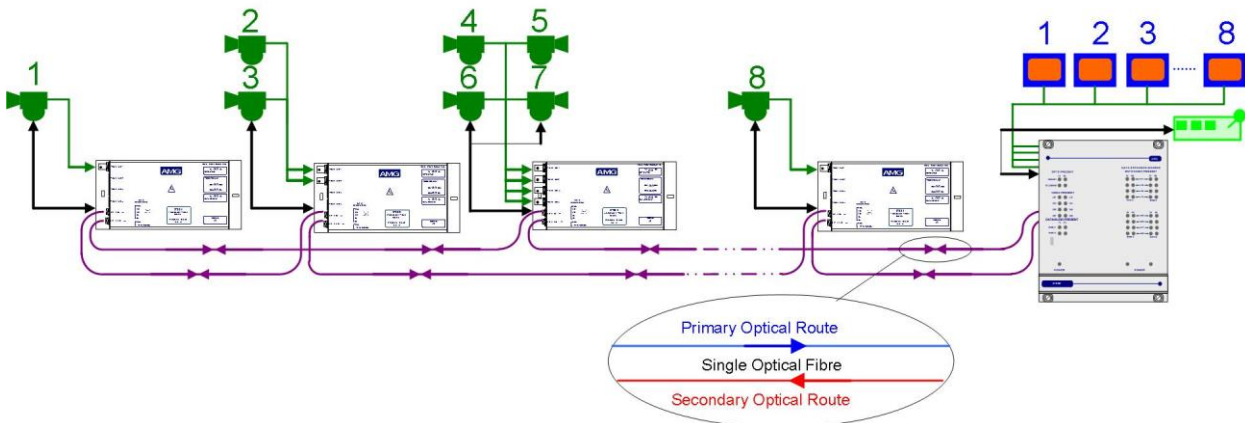

If a fibre link is broken, operation of the ring continues by making use of the secondary optical fibre route as below:

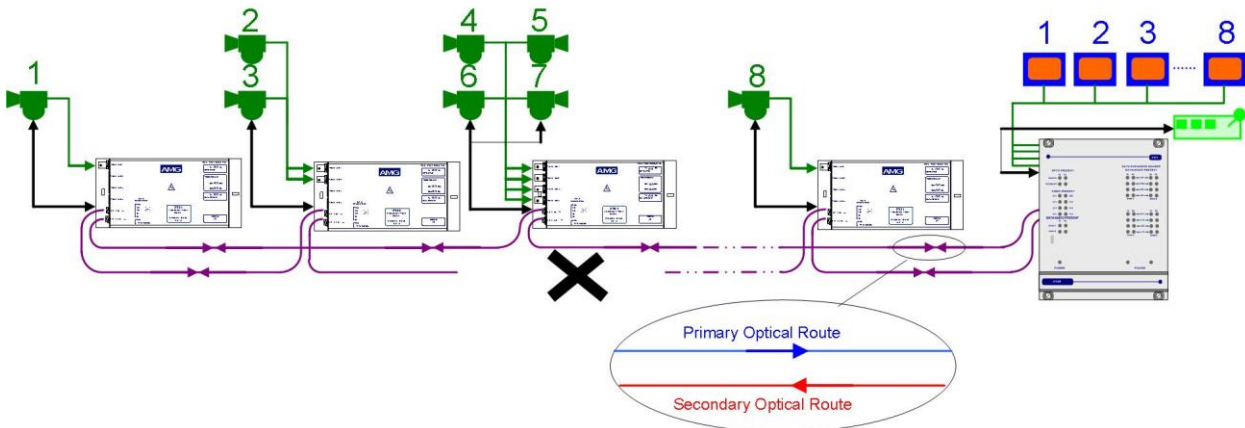

If multiple breaks occur, operation is maintained with all the units still physically connected to the receiver. For the scenario shown below camera signals and control would now be lost from cameras 1, 2 and 3 as there is now no physical connection between the transceivers and the receiver. However operation of cameras 4,5,6,7 and 8 remains fully functional.

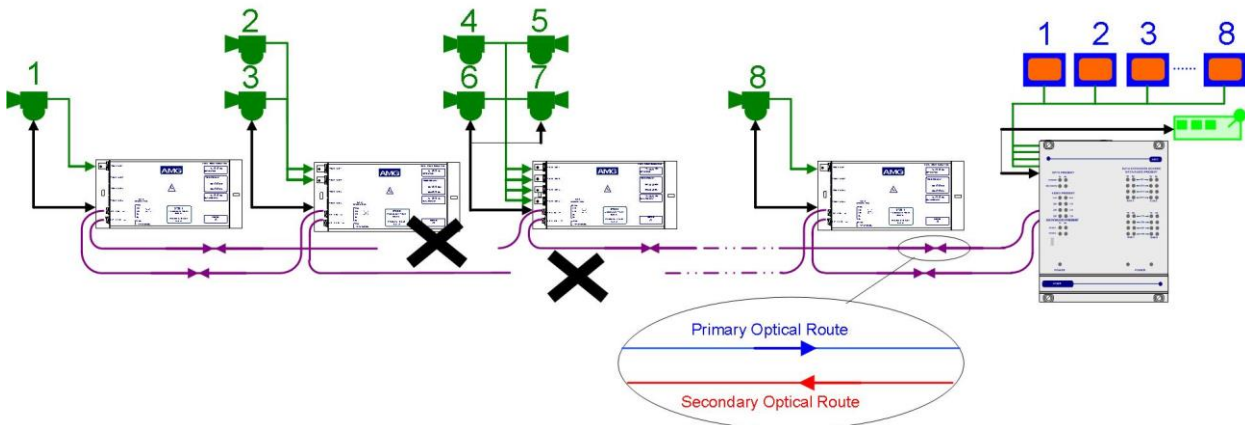

## Connections

---

### Video Output Connections

No. of channels.....	8
Connectors .....	75 ohm BNC Socket.
Output Impedance .....	75 ohm terminated.
Output Level .....	1 Volt p-p nominal
Frequency Response .....	10Hz to 7MHz.

### Optical Connections

#### PRIMARY OPTO OUT

Connector .....	LC/PC
Primary Optical Launch Power.....	-5dBm
Wavelength.....	1550nm
Secondary Optical Sensitivity.....	-22dBm
Wavelength.....	1310nm

#### PRIMARY OPTO IN

Connector .....	LC/PC
Primary Optical Sensitivity.....	-22dBm
Wavelength.....	1550nm
Secondary Optical Launch Power .....	-5dBm
Wavelength.....	1310nm

Optical Fibre ..... Multimode 50/125 or 62.5/125\*\*

\*\*Note: the transmission distance is limited by the bandwidth of the Multimode optical fibre. The optical data rate is 1.25Gbits/s. The maximum bandwidth specification at this data rate for Multimode fibre is 500m, although in most cases the units will operate successfully over longer fibre lengths. It is advisable however for distances greater than 500m, to have the optical fibre tested.

### Power Connection

Connector Type.....	2.1mm screw lock long power jack – centre positive
Connector Partno. ....	Switchcraft S761K, AMG G16125-00
Supply Voltage .....	13.5 to 18.0 Volts DC.
Maximum Power .....	5 Watts

### Data and Audio Channel Connections

Total No. of Data Channels ..... 2 channels

#### DATA CHANNEL A

Data Channel A .....	1 channel
Data Connector .....	RJ45

Channel A Interface     On Board Data Interface – RS232, RS422 or RS485. Selected by slide switch above the RJ45 connector.

- RS485 – switch position - high (closest to BNC connections)
- RS422 – switch position – middle
- RS232 – switch position – low (furthest from BNC connections)

#### DATA CHANNEL B

Data Channel B .....	1 channel
Data Connector .....	RJ45

Channel B Interface .....Defined by data/audio interface daughter board fitted into Slot 1 on main board and indicated by the 'x' in the AMG partno.

**Ethernet Connection**

Ethernet Data Connector .....RJ45  
Interface .....Auto-negotiation up to 100BASE-TX full duplex  
Ethernet Data Rate .....Maximum 50Mbits/s total Ethernet traffic on fibre

## Front Panel Indicators

---

### Power LED

Power .....	Green	-	unit powered
	Off	-	no power applied to unit

### Video Output LED's

Video Present CH1-8 .....	Green	-	video signal present on output BNC
	Org	-	channel present but no video on O/P BNC
	Off	-	no video channel present

### Fibre Optic LED's

Primary Opto Sync TX.....	Green	-	optical channel transmitting
	Off	-	optical channel not transmitting
Primary Opto Sync RX .....	Green	-	optical channel receiving
	Org	-	optical channel receiving but not sync.
	Off	-	optical channel not receiving
Secondary Opto Sync TX.....	Green	-	optical channel transmitting
	Off	-	optical channel not transmitting
Secondary Opto Sync RX .....	Green	-	optical channel receiving
	Org	-	optical channel receiving but not sync.
	Off	-	optical channel not receiving

### Low Speed Data LEDs

#### Channel A

Data Present TX (RS485 or RS422) ...	Green	-	logic zero (+V, -V) present on IN+, IN-
	Red	-	logic one (-V,+V) present on IN+, IN-
	Off	-	tri-state off or no connection on IN+, IN-
Data Present TX (RS232) .....	Green	-	logic zero (+V) present on input IN+
	Red	-	logic transitions present on input IN+
	Off	-	logic one (-V) present on input IN+

This represents the data signals being transmitted on the optical fibre

Data Present RX (RS485 or RS422)...	Green	-	logic zero (+V,-V) present on OUT+, OUT-
	Red	-	logic one (-V,+V) present on OUT+, OUT-
	Off	-	tri-state off or no connection on OUT+, OUT-
Data Present RX (RS232) .....	Green	-	logic zero (+V) present on OUT+
	Red	-	logic transitions present on OUT+
	Off	-	logic one (-V) present on OUT+

This represents the data signals being received on the optical fibre

#### Channel B (When RS232 data daughter board fitted)

Data Present TX.....	Green	-	logic zero (+V) present on IN+
	Red	-	logic transitions present on IN+
	Off	-	logic one (-V) present on IN+

This represents the data signals being transmitted on the optical fibre

Data Present RX.....	Green	-	logic zero (+V) present on OUT+
	Red	-	logic transitions present on OUT+
	Off	-	logic one (-V) present on OUT+

This represents the data signals being received on the optical fibre

**Channel B** (When RS485 / RS422 data daughter board fitted)

Data Present TX .....	Green	-	logic zero (+V, -V) present on IN+, IN-
	Red	-	logic transitions present on IN+, IN-
	Off	-	logic one (-V, +V) present on IN+, IN-

This represents the data signals being transmitted on the optical fibre

Data Present RX.....	Green	-	logic zero (+V, -V) present on OUT+, OUT-
	Red	-	logic transitions present on OUT+, OUT-
	Off	-	logic one (-V, +V) present on OUT+, OUT-

This represents the data signals being received on the optical fibre

**Channel B** (When audio daughter board fitted)

Audio Present TX.....	Green	-	audio present > -40dBm
	Red	-	audio present > 0dBm (overload at +6dBm)
	Off	-	audio not present or < -40dBm

This represents the audio signals being transmitted on the optical fibre

Audio Present RX .....	Green	-	audio present > -40dBm
	Red	-	audio present > 0dBm (overload at +6dBm)
	Off	-	audio not present or < -40dBm

This represents the audio signals being received from the optical fibre.



## ***Ethernet Operation***

---

In order for the AMG system to transmit Ethernet signals, an onboard RJ45 Ethernet interface or X16003 Ethernet interface adaptor should be fitted to all units in the ring.

The Ethernet interface can operate at either 10Mbits/s half duplex, or 100Mbit/s full duplex. When all the Ethernet interfaces around the ring are operating at 100Mbit/s full duplex the system behaves as a multi-port repeater. Data transmitted on any one port is transmitted out on all other ports with the minimum of delay or buffering. The nominal bandwidth available for Ethernet transmission within the ring is 100Mbit/s when Ethernet only, or 50MBit/s when the low speed data option is also used. If one node is transmitting, the entire bandwidth is available for this traffic. If multiple nodes transmit simultaneously on the ring, then the bandwidth is shared between each node as required. With similar traffic at each node the sharing would be nominally equal.

Although the limit for the number of video channels which can be transmitted around the ring is eight, up to 64 nodes can be attached for distributing Ethernet signals with the bandwidth sharing implemented. The units use Flow Control (Pause Frames) to limit the access to the ring to share the bandwidth and to ensure that no data is lost. When an Ethernet port is operating at 10Mbits/s half duplex, this port will now only receive data from a receive unit rather than all ports as when operating at 100Mbits/s full duplex.

The 100BaseT port does not implement MDI/MDIX; it should be connected with a straight though cable to an external switch port and with a cross over cable when connected directly to a PC or DTE.

## Data and Audio Channel Configuration

---

### Data and Audio Channel Configuration

The **AMG3684BxE-DR-SF** and rackmount equivalent **AMG3684BxER-DR-SF** sends and receives data to/from Channel A and Channel B. Channel A is a single data interface selectable by the user with the slide switch on the rear panel. Channel B carries a second channel of data / audio, the function and physical interface being determined by the type of daughter board fitted to the B Channel data slot.

### Data Interface Connections Channel A

RJ45 Pin No.	Channel A			Cat 5/6 Cable Colour Code T568B
	RS485 [switch low]	RS422 [switch mid]	RS232 [switch high]	
1		IN + (A)	GND	White/orange
2		IN - (B)	IN	Orange
3				White/green
4				Blue
5				White/blue
6				Green
7	IN/OUT + (A)	OUT + (A)	N/A	White/brown
8	IN/OUT - (B)	OUT - (B)	OUT	Brown

Note: (A) or (B) in brackets in above table refers to RS485 / RS422 data specification, not Channel A, Channel B.

### Data Channel A Configuration

Channel A is always present and allows for a RS232, RS422 (full duplex, four wire) or RS485 (half duplex, two wire) interface depending on the position of the switch located above the RJ45 connector. The switch signifies the presence of the X16004 Low Speed Data/Audio Interface Board. If there are LED's present on the RJ45 connector then an X16003 Ethernet Interface Board is fitted.

The data input for both the RS485 and the RS422 modes detects a tri-state input condition by monitoring the differential voltage level across the input. A differential level below 600mV positive or negative will be detected as a tri-state condition. A level above 600mV positive or negative will be detected as a logic 1 or logic zero respectively. It is important therefore to terminate the RS485 bus or the RS422 input bus using 120Ω if a pre-bias is present on the RS485 or RS422 bus.

A large number of third party equipment manufacturers apply a pre-bias on their RS485 bus. This pre-bias is applied by pulling one arm of the RS485 bus high (+5 volts) and the other arm low (0 volts) using high value resistors within the third party equipment. In order to ensure that the AMG equipment detects a tri-state condition, then these resistors should have a value above 5kΩ. If the third party bias resistors are less than 750Ω the bus can be double or triple terminated as required to ensure that a tri-state level is detected.

Note: The Data Channel A is shipped from the factory set up for RS485 operation unless otherwise requested.

### **Data / Audio Channel B Configuration**

Data Channel B is operational when fitted with the appropriate daughter board.

### **Data Interface Daughter Board Options**

The data interface daughter board options are as follows:

<b>Option Code 'x'</b>	<b>Part No.</b>	<b>Description</b>
0	X12542	4 Wire Audio Interface Daughter Board
1	X04057	RS422/485 Data Interface Daughter Board
2	X04049	RS232 Data Interface Daughter Board
3	X04058	20mA Current Loop Data Interface Daughter Board
4	X12579	TTL Data Interface Daughter Board
5	X12578	Contact Closure Data Interface Daughter Board
6	X13038	FTT10A Echelon Lonworks Data Interface Daughter Board

### **Audio / Data Interface Connections RJ45 - Channel B**

RJ45 Channel B low speed data/audio interface connections:

<b>RJ45 Pin No.</b>	<b>Channel B</b>	<b>Cat 5/6 Cable Colour Code T568B</b>
	<b>Data / Audio Daughter Board</b>	
1		<b>White/orange</b>
2		<b>Orange</b>
3	OUT + (A)	<b>White/green</b>
4	IN - (B)	<b>Blue</b>
5	IN + (A)	<b>White/blue</b>
6	OUT - (B)	<b>Green</b>
7		<b>White/brown</b>
8		<b>Brown</b>

Note: (A) or (B) in brackets in above table refers to RS485 / RS422 data specification, not Channel A, Channel B.

## **Physical Information**

---

### **Dimensions**

Height.....112mm  
Width.....170mm (excluding connectors)  
Depth .....70mm  
Weight.....1000grams

### **Mounting Details**

The AMG unit is supplied with a clip-on mounting bracket which should be attached to a panel or wall using 2 off 4.0mm screws, see diagram on page 1 for dimensions. The unit is clipped into the mounting bracket, and is then held firmly in position.

### **Removal / replacement from / to the Case**

Note: - The AMG unit PCB's are static sensitive. Handle with proper care and use normal electrostatic discharge (ESD) procedures. Use properly grounded protection (for example, wrist straps) when handling the PCB.

To remove units from the case to access the data expansion boards and the daughter boards, remove the 2 or 4 fixing screws on the rear panel and slide the PCB's out of the case. Ensure that the fibres do not snag or get trapped.

To replace the PCB's into the case, slide the PCB's gently into the case aligning the boards with the appropriate slots. Ensure that the fibre do not snag or get trapped.

## **Safety**

---

AMG Optical Fibre Products use Class 1 laser systems in accordance with EN 60825-2:2000.

It is always advisable to follow good practice when working with optical fibre systems. This includes:

- Do not stare with unprotected eyes or with any unapproved collimating device at fibre ends or connector faces, or point them at other people.
- Use only approved filtered or attenuating viewing aids

For other safety issues and advice on good practice associated with optical fibre systems, please see EN 60825-2:2000 or your local safety officer.

## **Maintenance and Repair**

---

There are no user serviceable parts within AMG products. See unit data sheet for full specification. In case of problem or failure, please call your local support centre or contact: **AMG Systems Ltd.** at 3 The Omega Centre, Stratton Business Park, Biggleswade, Beds., SG18 8QB, UK.

Phone	+44 (0) 1767 600 777
Technical Support	+44 (0) 1767 604 491
Email	techsupport@amgsystems.com